

# BPH

## Compact Plasma Cutting System

*The tough little machine for ducting and light cutting.*

*A high rail machine ideal for HVAC ducting work and other light sheet work but built with extra strength and precision so it can be upgraded to high definition plasma cutting for material up to 40 mm.*



### **Simple operation**

*The Baykal compact is fitted with a very simple control so that new or occasional users can be trained in minutes*

## Easy programming

Offered with a range of programming tools from Lantek the most complicated sheet-metal developments of ducting components hoods etc. can be produced in seconds and downloaded to the machine for immediate cutting or combined

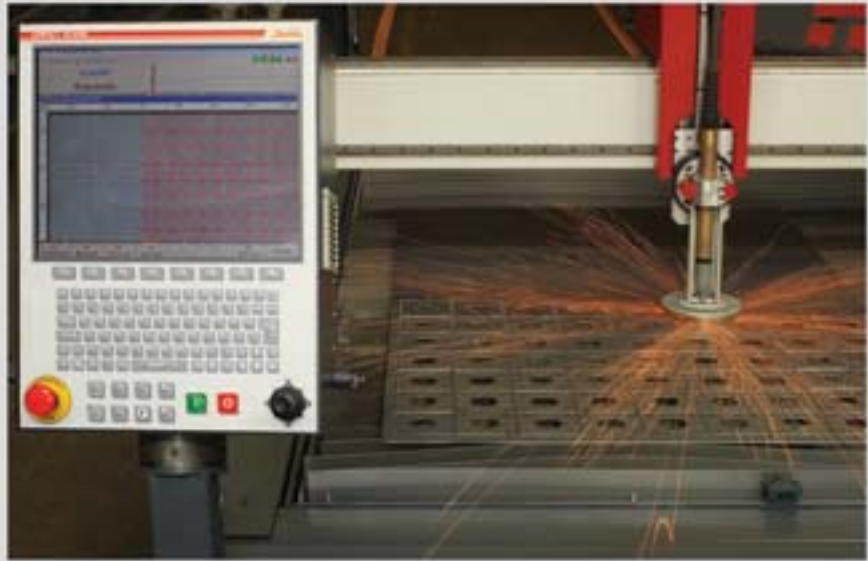

## Rugged structure

Featuring a fully machined gantry and base with linear bearings on both longitudinal rails this machine is built to work hard and long. Because of its unitary design there is no need for a complicated installation and if necessary the machine can be readily moved around the workshop to suit changing workloads.

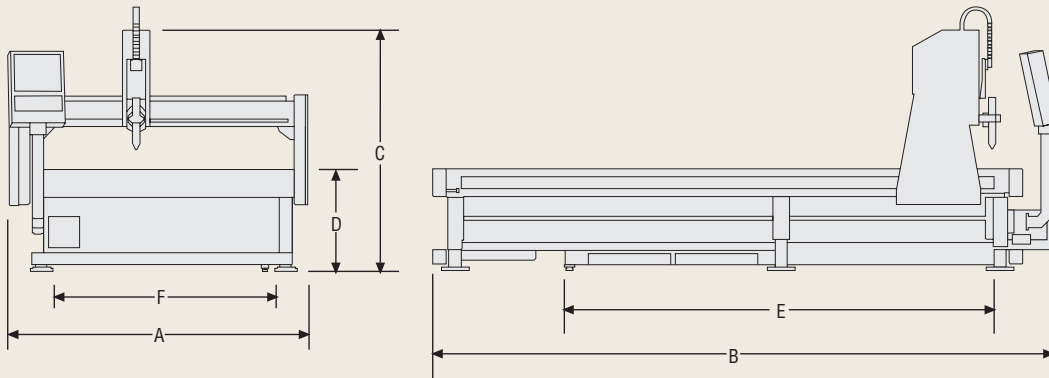

TYPE	Machine Width (A) (mm)	Machine Length (B) (mm)	Machine Height (C) (mm)	Table Height (D) (mm)	Machine Cutting Width (E) (mm)	Machine Cutting Length (F) (mm)	Machine Weight (kg)
BPH-Compact 1503	2140	4450	1750	750	3110	1600	2200

Design and specifications are subject to change without notice.