

DELTA 50 Plus



PQi



CNC-C



CNC-i



DELTA 50 Plus + SI (R)

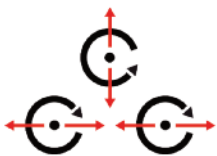



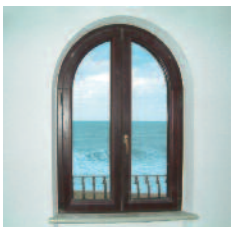

tauring
TOP PERFORMING



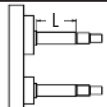
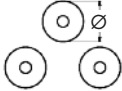
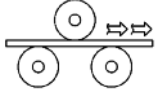
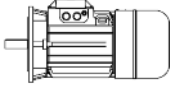

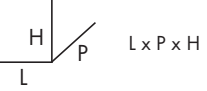

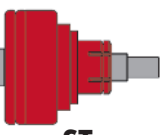
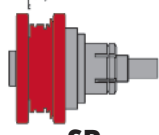

DELTA 50 Plus

DATI TECNICI - TECHNICAL DATA - DONNEES TECHNIQUES - TECHNISCHE DATEN - DATOS TECNICOS

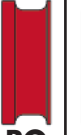

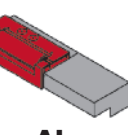
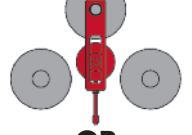
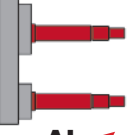
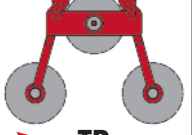
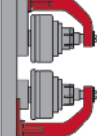
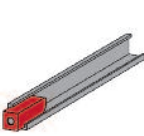
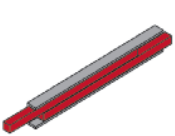
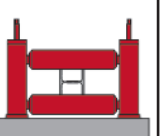
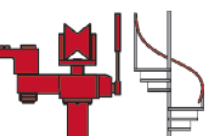
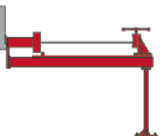
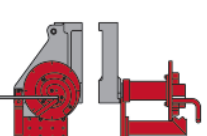















 mm 115	 mm 175	 min ⁻¹ 8	 kW 3,75	 cm 93	 cm 103x135x150	 kg 590
---	---	--	--	---	---	---

ACCESSORI - ACCESSORIES - ACCESSOIRES - AUSRÜSTUNG - UTILLAJES

 ST S	 SP R	 RT R	 RO R	 RQ R	 AC R	 AI R	 QR R	 AL R	 TR R
 SI R	 ANC R	 ANL R	 DRL R	 ROS - ROS PLUS R	 TOR R	 ATV R	 ARC 50 R		

S = STANDARD R = OPTIONAL

CAPACITA' MASSIME - MAXIMUM PERFORMANCES - PRESTATIONS MAXIMALES - HOCHLEISTUNGEN - CAPACIDADES MAXIMAS

POSITION	mm	R. mm	S - R	POSITION	mm	R. mm	S - R
 1a	75 x 30 120 x 30	250 300	ST ST - AL - TR	 9b	60,3 x 5 (2") 76,1 x 5 (2"1/2)	600 1000	RT RT - SI
 1b	60 x 20 80 x 15	500 900	ST ST - SI	 9c	50 55	500 900	RT RT - SI
 2a	40 50	600 1000	ST ST - SI	 10a	80 x 40 x 3 100 x 40 x 3	450 1000	ST/RQ ST/RQ - SI
 3a	50 x 50 x 8 60 x 60 x 10	500 700	ST ST - SI	 10b	70 x 50 x 3 80 x 40 x 3	600 1000	ST/RQ ST/RQ - SI
 3b	50 x 50 x 8 60 x 60 x 10	500 700	ST ST - AL - SI	 11a	50 x 50 x 4 60 x 60 x 5	900 1300	ST/RQ ST/RQ - SI
 5a	60 x 60 x 7 80 x 80 x 10	250 400	ST ST - SI	 12a	80 x 40 x 3 100 x 40 x 3	450 1000	RO RO - SI
 5b	60 x 60 x 8 80 x 80 x 10	250 400	ST ST - SI	 12b	70 x 50 x 3 80 x 40 x 3	600 1000	RO RO - SI
 6a	UPN 65 UPN 120	500 700	ST ST - AL - TR	 13a	a60 x b90 x c50	500	SP - SI
 6b	UPN 80 UPN 120	500 700	ST ST - AL - TR	 13b	a70 x b96 x c30	500	SP - SI

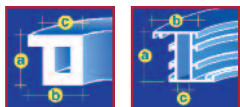

13a - Fe 13b - Al

I dati riportati sono puramente indicativi e suscettibili di variazioni senza preavviso, quindi non possono essere ritenuti vincolanti. / Les informations données sont approximatives et elles peuvent varier sans préavis. Tout ça signifie que ces informations ne sont pas engageantes. / The data are merely indicative and they can vary without notice, so they cannot be considered as binding. / Die Angaben sind ganz approximativ und können ohne vorherige Benachrichtigung geändert werden und daher sind nicht verbindlich. / Los datos citados tienen que ser considerados como puramente indicativos y pueden cambiar sin previo aviso. Por lo tanto, no seran un vinculo.